



ZT

Parts Manual



Models

915146 – ZT 34
(SN 030000+)

915148 – ZT 42
(SN 030000+)

915150 – ZT 50
(SN 030000+)

915168 – ZT 34 CARB
(SN 030000+)

915170 – ZT 42 CARB
(SN 030000+)



The use of any gasoline exceeding 10% ethanol (E10) or 10% MTBE will void the product warranty.
L'utilisation d'une essence contenant plus de 10% d'éthanol (E10) ou de 10% de MTBE annulent la garantie.
El uso de cualquier otro tipo de gasolina con un porcentaje superior al 10% de etanol (E10) o al 10% de MTBE invalidará la garantía del producto.

THE MANUAL

Before you operate your unit, carefully and completely read manuals supplied with the unit. The contents will provide you with an understanding of safety instructions and controls during normal operation and maintenance.

For your safety and the safety of others always read, understand, and follow all DANGER, WARNING, and CAUTION messages found in manuals and on safety decals.

Hardware descriptions are given in decimals.

Decimals to Fractions			
.063	1/16	.563	9/16
.125	1/8	.625	5/8
.188	3/16	.688	11/16
.250	1/4	.750	3/4
.313	5/16	.813	13/16
.375	3/8	.875	7/8
.438	7/16	.938	15/16
.500	1/2	1.00	1

SERVICE AND REPLACEMENT PARTS

When ordering replacement parts or making service inquiries, know the Model and Serial numbers of your unit and engine.

Numbers are located on the product registration card in the unit literature package. They are printed on a serial number label, located on the frame of your unit.

• Record Unit Model and Serial numbers here:

• Record Engine Model and Serial numbers here:

UNAUTHORIZED REPLACEMENT PARTS

Use only Gravelly replacement parts. The replacement of any part on this vehicle with anything other than a Gravelly authorized replacement part may adversely affect the performance, durability, or safety of this unit and may void the warranty. Gravelly disclaims liability for any claims or damages, whether warranty, property damage, personal injury or death arising out of the use of unauthorized replacement parts.

PRODUCT REGISTRATION

The Gravelly dealer must register the product at the time of purchase. Registering the product will help the company process warranty claims or contact you with the latest service information. All claims meeting requirements during the limited warranty period will be honored, whether or not the product registration card is returned. Keep a proof of purchase if you do not register your unit.

Customer Note: If Dealer does not register your product, please fill out, sign and return the product registration card to Gravelly or go to www.gravelly.com.

YOUR SATISFACTION IS IMPORTANT

Questions? Please follow these helpful steps:

1. Refer to the manuals supplied with your unit.

They will guide you through safe and proper operation and maintenance.

They contain specifications on your unit.

If your questions are not answered in these manuals, go to step number two.

2. Contact Your Dealer.

Our dealers will be happy to supply any service or advice required to keep your unit operating at peak efficiency.

A factory trained staff is available to support your equipment needs. They stock genuine Gravelly parts and lubricants manufactured with the same precision and skill as the original.

If your questions are not resolved by the support staff, ask for the manager or owner.

When contacting your Dealer supply your model and serial numbers.

TO SPEED PARTS ORDERING:

1. Know the model and serial numbers of your unit.

2. Know the part number required.

3. Know the quantity required.

4. Know the part description.

MODELS

Domestic

Model 915146 (ZT 34)

Briggs & Stratton with 34" Mower
Serial No. 030000 and up

Model 915148 (ZT 42)

Kawasaki with 42" Mower
Serial No. 030000 and up

Model 915150 (ZT 50)

Kawasaki with 50" Mower
Serial No. 030000 and up

Model 915168 (ZT 34 CARB)

Briggs & Stratton with 34" Mower
Serial No. 030000 and up

Model 915170 (ZT 42 CARB)

Kawasaki with 42" Mower
Serial No. 030000 and up

TABLE OF CONTENTS

DECALS

Decals 4

MAIN FRAME AND TRANSAXLES

Frame, Hood, Fenders, Casters and Tires. 6

Seat and Seat Support. 10

Transaxle, Dump Valves and Rear Wheels 14

OPERATOR CONTROLS

Parking Brake. 16

Steering Controls 18

FUEL TANKS AND ENGINE

Engine, Exhaust, Belts and Idlers 20

Fuel Tank 22

ELECTRICAL SYSTEM

Continuity Diagram. 23

Electrical System 24

Wiring Diagram 26

MOWER DECKS

Mower Deck Lift 28

Mower Deck, Belt and Idlers 30

Belt Covers and Blades 34

DECALS – SAFETY

Model 915146, 148, 150, 168, 170

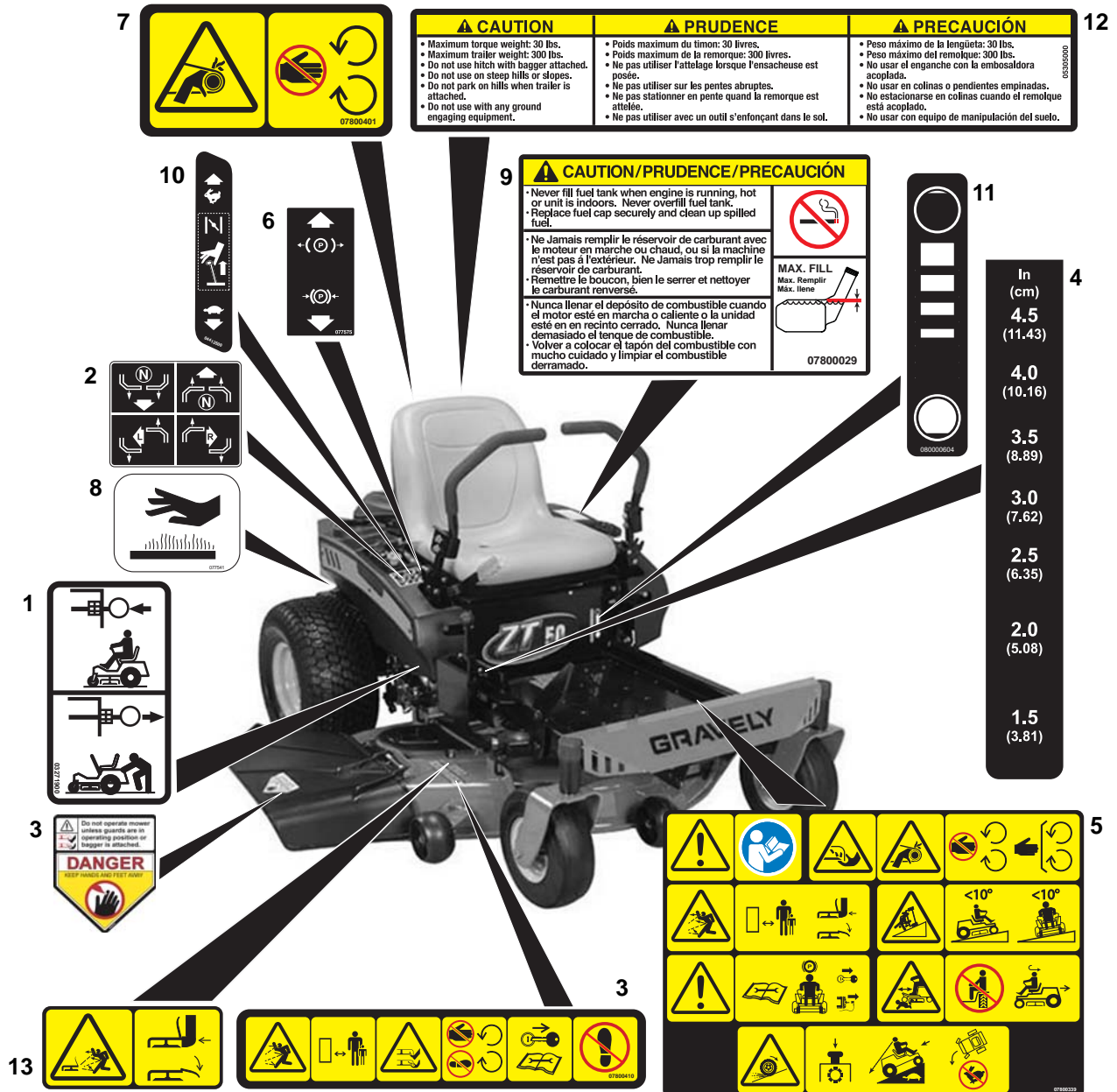

Item	Part No.	Qty.	Description
1	03271900	2	Decal, Transmission Disconnect
2	07757600	1	Decal, Instructional Steering
3	07800410	2	Decal, Safety – Mower Deck
4	07800334	1	Decal, Cut Height
5	07800403	1	Decal, Safety – Main
6	07757500	1	Decal, Parking Brake Lever
7	07800401	1	Decal, Safety – Guarding
8	07754100	2	Decal, Hot Surface
9	07800029	1	Decal, Fuel Warning
10	05301400	1	Decal, Throttle Control (915146, 168)
	04413500	1	Decal, Throttle/Choke Combo (915148, 150, 170)
11	08000604	1	Decal, Fuel Level
12	05305000	1	Decal, Trailer Hitch (915148, 150, 170)
13	07800402	1	Decal, Safety – Deck Guarding

DECALS – STYLE

Model 915146, 148, 150, 168, 170



Item	Part No.	Qty.	Description
1	07800101	1	Decal, ZT 34 (915146, 168)
	07800210	1	Decal, ZT 42 (915148, 170)
	07800211	1	Decal, ZT 50 (915150)
2	08000507	1	Decal, Gravely Heritage, Small

FRAME, HOOD, FENDERS, CASTERS AND TIRES

Model 915168, 170

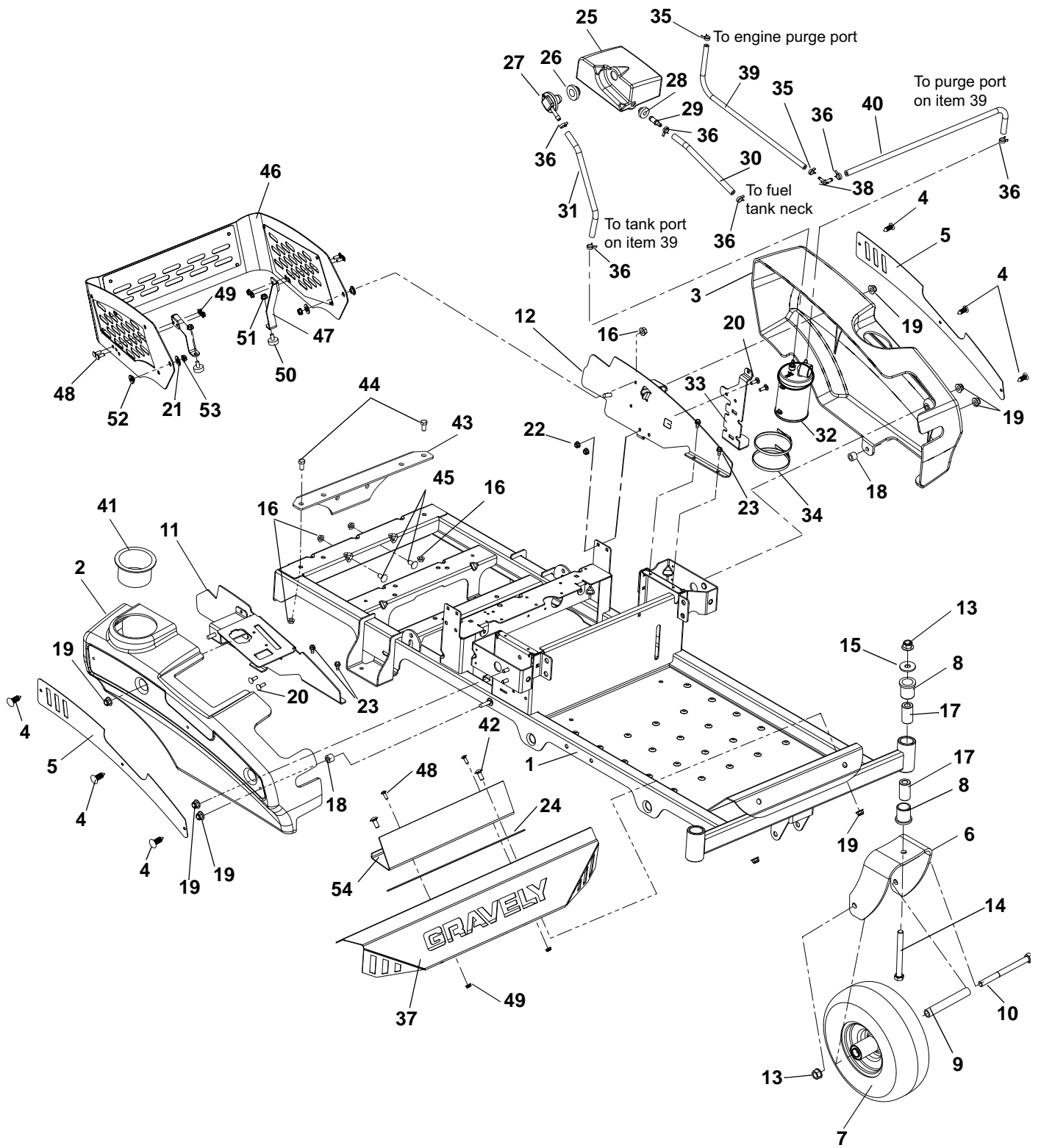

FRAME, HOOD, FENDERS, CASTERS AND TIRES

Model 915168, 170

Item	Part No.	Qty.	Description
1	51525900	1	Weldment, Frame
2	03768600	1	Fender, Right Hand
3	03768700	1	Fender, Left Hand
4	07500125	6	Rivet, Nylon
5	04717553	2	Plate, Fender
6	03368553	2	Fork, Caster
7	07100124	2	Wheel/Tire Assembly, 11 x 4-5
8	05500934	4	Bushing, Flange 1.00 x 1.25 x 1.50 x 1.50
9	00278500	2	Spacer, Wheel
10	05964400	2	Bolt, Hex .50-13 x 6.50
11	04717353	1	Weldment, Fender Mount Right Hand
12	04717253	1	Weldment, Fender Mount Left Hand
13	06543600	4	Nut, Locking Top Flange .50-13
14	05962200	2	Bolt, Hex .50-13 x 5.00
15	06436400	2	Washer, Flat Steel .511 x 1.441 x .125
16	06542000	6	Nut, Locking Top Flange .38-16
17	00363100	4	Spacer, Caster
18	08553700	2	Bushing, Sleeve .391 x .688 x .52
19	06545400	8	Nut, .31-18 Nyloc Flange
20	06219900	4	Bolt, Round Head Square Neck .25-20 x .75
21	06443300	2	Washer, Flat Nylon .52 x 1.00 x .08
22	06500012	4	Nut, .25-20 Nyloc Flange
23	07412000	4	Screw, Tapping .25-20 x .50 Hex Washer Head Thread
24	03833800	1	Grip, Adhesive (1" x 16" BLK)
25	04400000	1	Tank, ZT/Waw Fuel Exp.
26	04082700	1	Grommet, Remote Vent Nitrile
27	04068910	1	Vent, Roll-Over (.25" ID Hose)
28	07500206	1	Bushing, Flange .375 x 1.062 x .625 R
29	04382700	1	Fitting, Straight Fuel
30	03278100	7"	Hose, .25 Low-Perm Bulk Gas
31	03278100	10"	Hose, .25 Low-Perm Bulk Gas
32	04082500	1	Carbon Canister, 300CC
33	04086551	1	Bracket, Mount, Canister BBZ
34	04102900	2	Plastic Tie Strap Large
35	04097700	2	Clamp, Hose Spring .188
36	03278800	6	Clamp, Hose Wire .490/.510 x .116
37	04717053	1	Foot Rest
38	04097000	1	Fitting, 3/16 x 1/4 90 Deg Vac
39	03375900	7"	Hose, .188 Low Perm Bulk (915168)
	03375900	11"	Hose, .188 Low Perm Bulk (915170)
40	03278100	27"	Hose, .25 Low Perm Bulk Gas (915168)
	03278100	30.5"	Hose, .25 Low Perm Bulk Gas (915170)
41	04196270	1	Cupholder
42	06215700	2	Bolt, Round Head Square Neck .31-18 x .75
43	03853851	1	Plate, BBZ Hitch Kit Plate (915170)
44	05959400	2	Bolt, Hex .38-16 x .75 (915170)
45	06223900	2	Bolt, Round Head Square Neck .31-16 x .75 (915170)
46	51526600	1	Assembly, Engine Wrap
47	04716951	2	Bracket, Engine Wrap Foot
48	06220600	6	Bolt, Round Head Square Neck .25-20 x .50
49	06500710	6	Nut, Center Lock Flange .25-20
50	07533600	2	Bumper, Rubber
51	06530400	2	Nut, Serrated Flange .31-18
52	05501127	2	Bushing, Flange .325 x .499 x .3 x .875
53	06528700	2	Nut, Center Lock Flange .31-18
54	04717151	1	Plate, Back Foot Rest

FRAME, HOOD, FENDERS, CASTERS AND TIRES

Model 915146, 148, 150

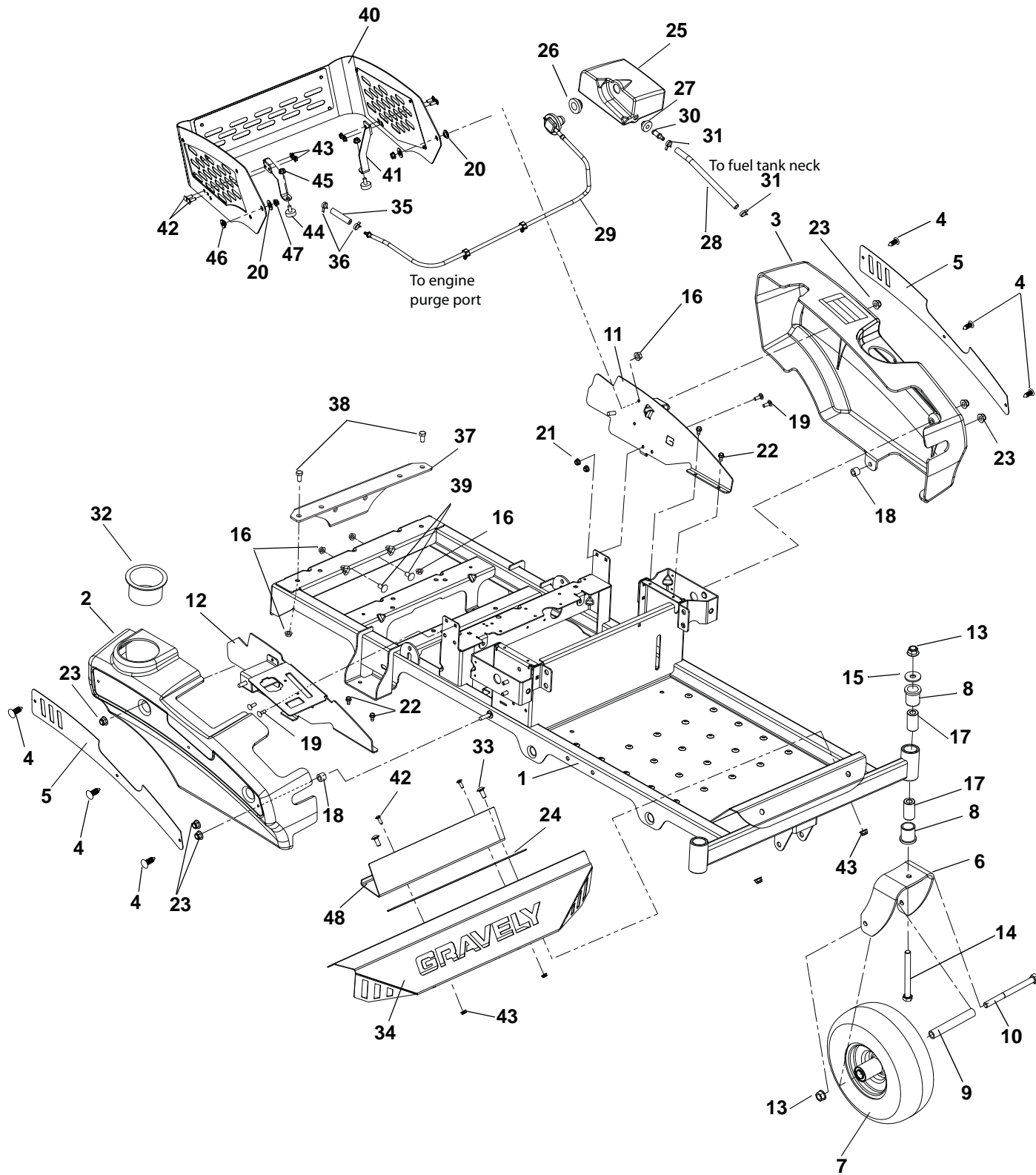

FRAME, HOOD, FENDERS, CASTERS AND TIRES

Model 915146, 148, 150

Item	Part No.	Qty.	Description
1	51525900	1	Weldment, Frame
2	03768600	1	Fender, Right Hand
3	03768700	1	Fender, Left Hand
4	07500125	6	Rivet, Nylon
5	04717553	2	Plate, Fender
6	03368553	2	Fork, Caster
7	07100124	2	Wheel/Tire Assembly, 11 x 4-5
8	05500934	4	Bushing, Flange 1.00 x 1.25 x 1.50 x 1.50
9	00278500	2	Spacer, Wheel
10	05964400	2	Bolt, Hex .50-13 x 6.50
11	04717353	1	Weldment, Left Hand Fender Mount
12	04717253	1	Weldment, Right Hand Fender Mount
13	06543600	4	Nut, Locking Top Flange .50-13
14	05962200	2	Bolt, Hex .50-13 x 5.00
15	06436400	2	Washer, Flat Steel .511 x 1.441 x .125
16	06542000	6	Nut, Locking Top Flange .38-16
17	00363100	4	Spacer, Caster
18	08553700	2	Bushing, Sleeve .391 x .688 x .52
19	06219900	4	Bolt, Round Head Square Neck .25-20 x .75
20	06443300	2	Washer, Flat Nylon .52 x 1.00 x .08
21	06500012	4	Nut, Locking Top Flange .25-20
22	07412000	4	Screw, Tapping .25-20 x .50 Hex Washer Head Thread
23	06545400	8	Nut, Locking Nylon Flange .31-18
24	03833800	1	Grip, Adhesive (1" x 16" BLK)
25	04400000	1	Tank, ZT/Waw Fuel Expansion
26	04082700	1	Grommet, Remote Vent Nitrile
27	07500206	1	Bushing, Flange .375 x 1.062 x .625
28	03278100	1	Hose, .25 Low-Perm Bulk Gas (7 inches)
29	04382500	1	Assembly, Fuel Vent – Kohler, Briggs and Stratton (915146)
	04382600	1	Assembly, Fuel Vent – Kawasaki (915148, 150)
30	04382700	1	Fitting, Straight Fuel
31	03278800	2	Clamp, Hose Wire .490/.510 x .116
32	04192700	1	Cupholder, Snap-In, 3.75 OD
33	06215700	2	Bolt, Round Head Square Neck .31-18 x .75
34	04717053	1	Foot Rest
35	03375900	NA	Hose, .188 Low-PERM Bulk Gas (as required)
36	04097700	2	Clamp-Hose, Spring .188
37	03853851	1	Plate, BBZ Hitch Kit Plate (915148, 150)
38	05959400	2	Bolt, Hex .38-16 x .75 (915148, 150)
39	06223900	2	Bolt, Round Head Square Neck .31-16 x .75 (915148, 150)
40	51526600	1	Assembly, Engine Wrap
41	04716951	2	Bracket, Engine Wrap Foot
42	06220600	6	Bolt, Round Head Square Neck .25-20 x .50
43	06500710	6	Nut, Center Lock Flange .25-20
44	07533600	2	Bumper, Rubber
45	06530400	2	Nut, Serrated Flange .31-18
46	05501127	2	Bushing, Flange .325 x .499 x .3 x .875
47	06528700	2	Nut, Center Lock Flange .31-18
48	04717151	1	Plate, Back Foot Rest

SEAT AND SEAT SUPPORT

Model 915146, 168

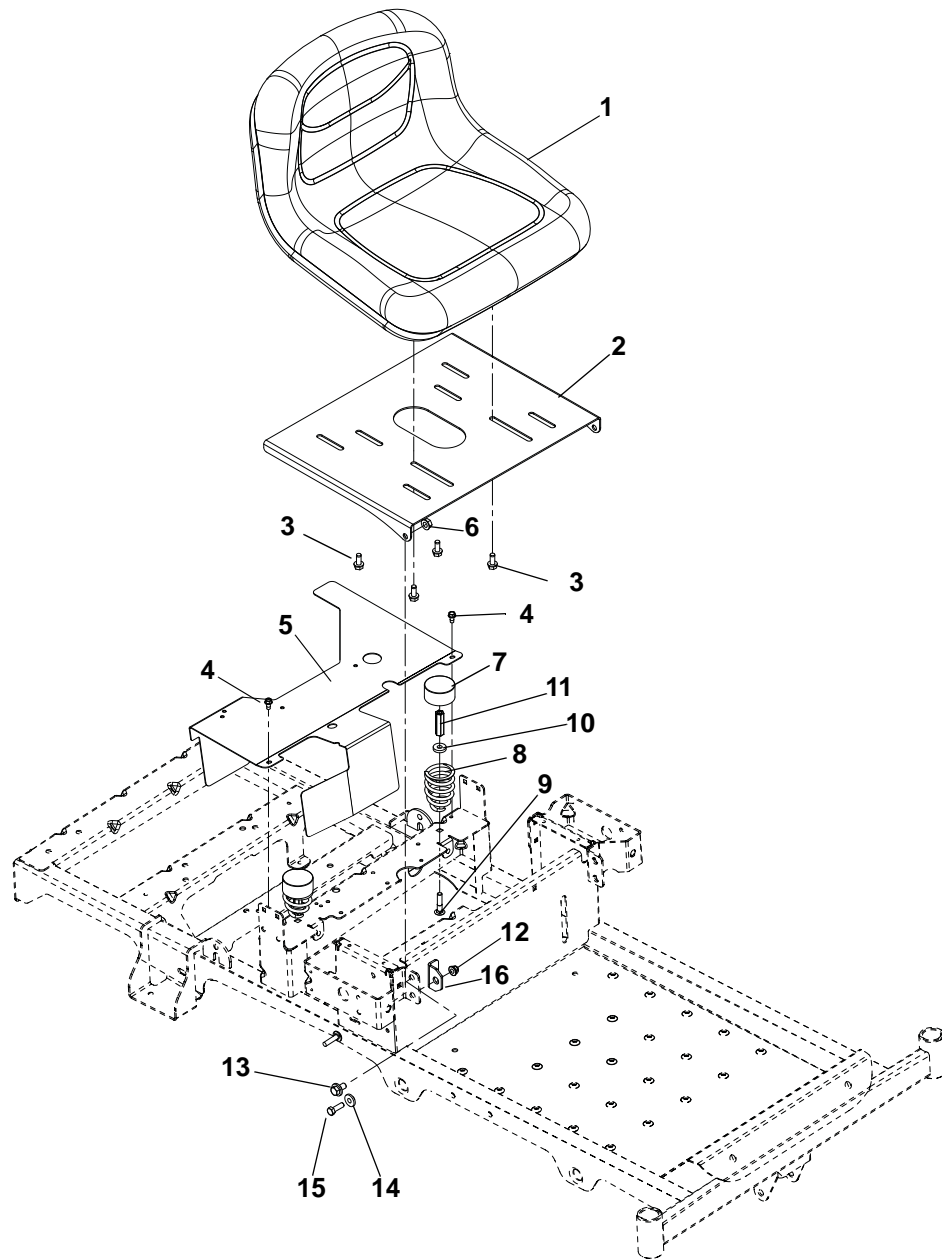

SEAT AND SEAT SUPPORT

Model 915146, 168

Item	Part No.	Qty.	Description
1	03795800	1	Seat, 13 in Grey
2	03782051	1	Seat Plate
3	05900033	4	Bolt, Hex 5/16-18 x 3/4
4	07412000	2	Screw, Tapping .25-20 x .50 Hex Washer Head Thread
5	03753351	1	Guard, Fan
6	06542000	2	Nut, .38-16 Locking Top Flange
7	00337700	2	Hub Cap
8	08300021	2	Spring, Seat
9	06212100	2	Bolt, Round Head Square Neck .31-18 x 1.50
10	06439100	2	Washer, Flat Steel .328 x .87 x .179
11	06500015	2	Nut, Coupling 5/16-18 x 1.75
12	06545400	2	Nut, 5/16-18 Flange Nyloc
13	07056700	2	Bolt, Shoulder .375-16 x .135
14	01305900	2	Bushing, Flange .325 x .499 x .26 x .88
15	05946900	2	Bolt, Hex .31-18 x 1.00
16	03798751	2	Bracket, Seat Stop

SEAT AND SEAT SUPPORT

Model 915148, 150, 170

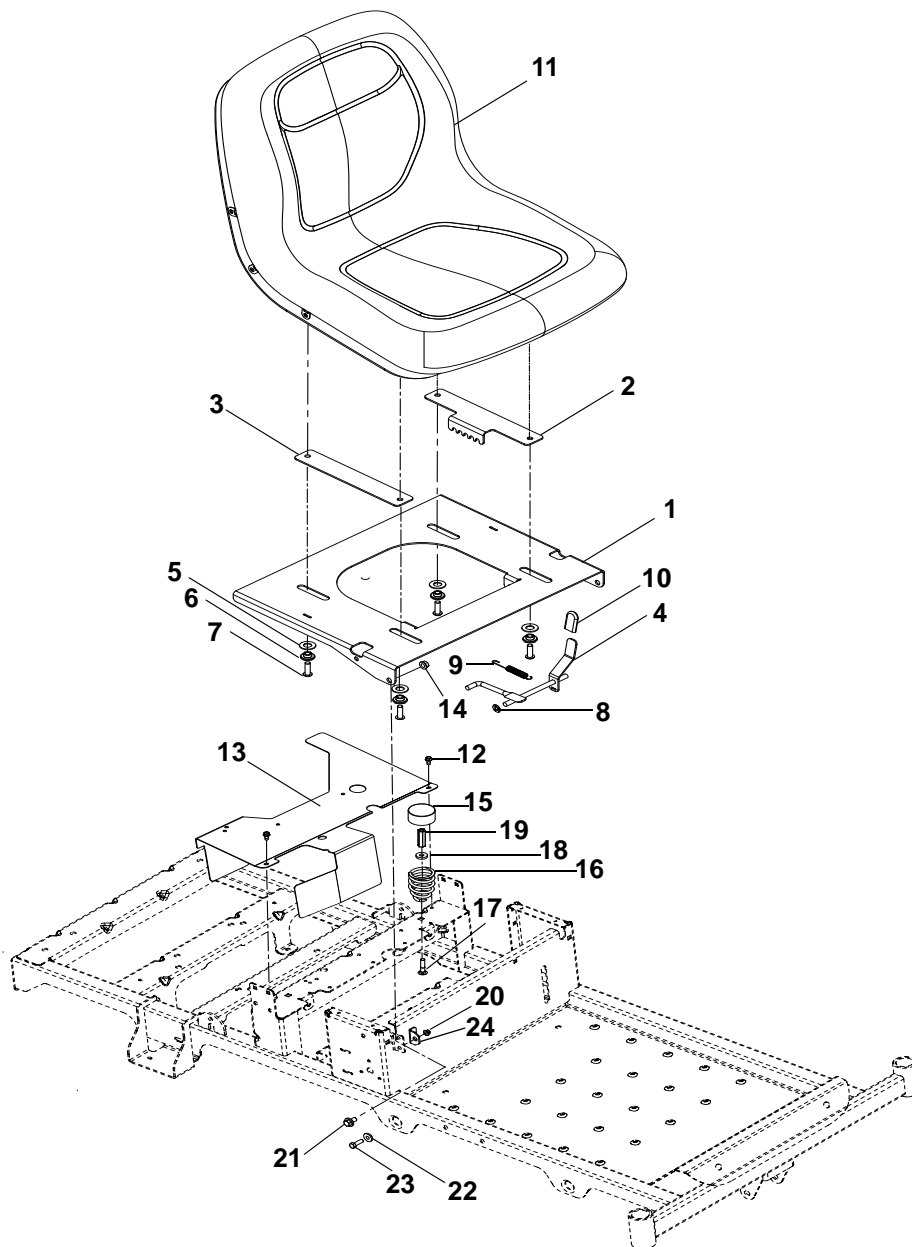

SEAT AND SEAT SUPPORT

Model 915148, 150, 170

Item	Part No.	Qty.	Description
1	04376251	1	Plate, Adjustable Seat
2	04376951	1	Plate, Adjustable Seat Track
3	04377051	1	Plate Adjustable Seat Slide
4	04377167	1	Weldment, Adjustable Seat Latch
5	06439200	4	Washer, Flat Steel .505 x 1.00 x .062
6	05514800	4	Bushing, Flange .32 x .500 x .344 x .880
7	05901508	4	Screw, Socket Head, Button Head .31-18 x 1.00
8	06514900	1	Push Nut 5/16
9	08321100	1	Weldment, Spring Tension .043 x .44 x 3.31, 5.8
10	04396600	1	Grip, Seat Lever, Grey
11	04278000	1	Seat, Milsco XB180 Grey
12	07412000	2	Screw, Tapping .25-20 x .50 Hex Washer Head Thread
13	03753351	1	Guard, Fan
14	06542000	2	Nut, .38-16 Locking Top Flange
15	00337700	2	Hub Cap
16	08300021	2	Spring, Seat
17	06212100	2	Bolt, Round Head Square Neck .31-18 x 1.50
18	06439100	2	Washer, Flat Steel .328 x .87 x .179
19	06500015	2	Nut, Coupling 5/16-18 x 1.75
20	06545400	2	Nut, 5/16-18 Flange Nyloc
21	07056700	2	Bolt, Shoulder .375-16 x .135
22	01305900	2	Bushing, Flange .325 x .499 x .26 x .88
23	05946900	2	Bolt, Hex .31-18 x 1.00
24	03798751	2	Bracket, Seat Stop

TRANSAXLE, DUMP VALVES AND REAR WHEELS

Model 915146, 148, 150, 168, 170

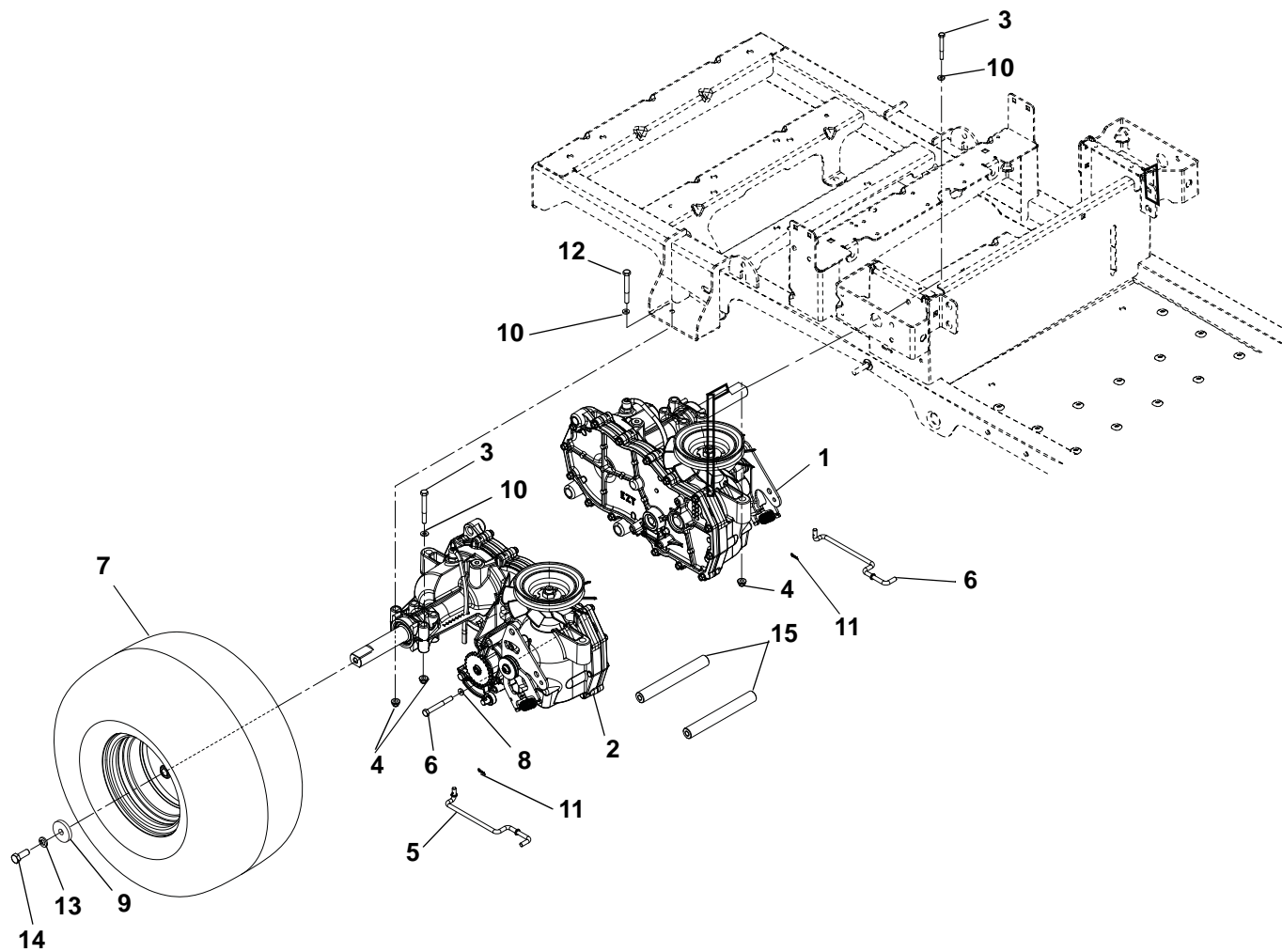

TRANSAXLE, DUMP VALVES AND REAR WHEELS

Model 915146, 148, 150, 168, 170

Item	Part No.	Qty.	Description
1	03872300	1	Transaxle, Left Hand EZT D-Shaft (915146, 168)
	04382300	1	Transaxle, Left Hand EZT D-Shaft Long (915148, 150, 170)
2	03872400	1	Transaxle, Right Hand EZT D-Shaft (915146, 168)
	04382400	1	Transaxle, Right Hand EZT D-Shaft Long (915148, 150, 170)
3	05963700	4	Bolt, Hex .31-18 x 2.25
4	06545400	8	Nut 5/16-18 Flange Nyloc
5	03762700	1	Dump Valve, Right Hand
6	03762800	1	Dump Valve, Left Hand
7	07100809	2	Tire Assembly 18 x 6.5-8 2 Ply DSHAFT (915146, 168)
	07100928	2	Tire/Wheel Assembly, 18 x 8.5-8 Center (915148, 170)
	07100929	2	Tire/Wheel Assembly, 18 x 9.50-8 Offset (915150)
8	06444000	4	Washer, Flat Steel .406 x 1.00 x .188
9	06400006	2	Washer, Flat Steel .406 x 1.50 x .245
10	06435700	8	Washer, Flat Steel .38 x .875 x .083
11	06701900	2	Pin, Hair, Internal .06 x .18 x .77
12	05960600	4	Bolt, Hex .31-18 x 2.75
13	06308800	2	Washer, Locking .38 x .094 Regular
14	05900013	2	Bolt, Hex .38-16 x 1.00 YWZC EP30
15	03762067	2	Shaft, Transaxle Brace

PARKING BRAKE

Model 915146, 148, 150, 168, 170

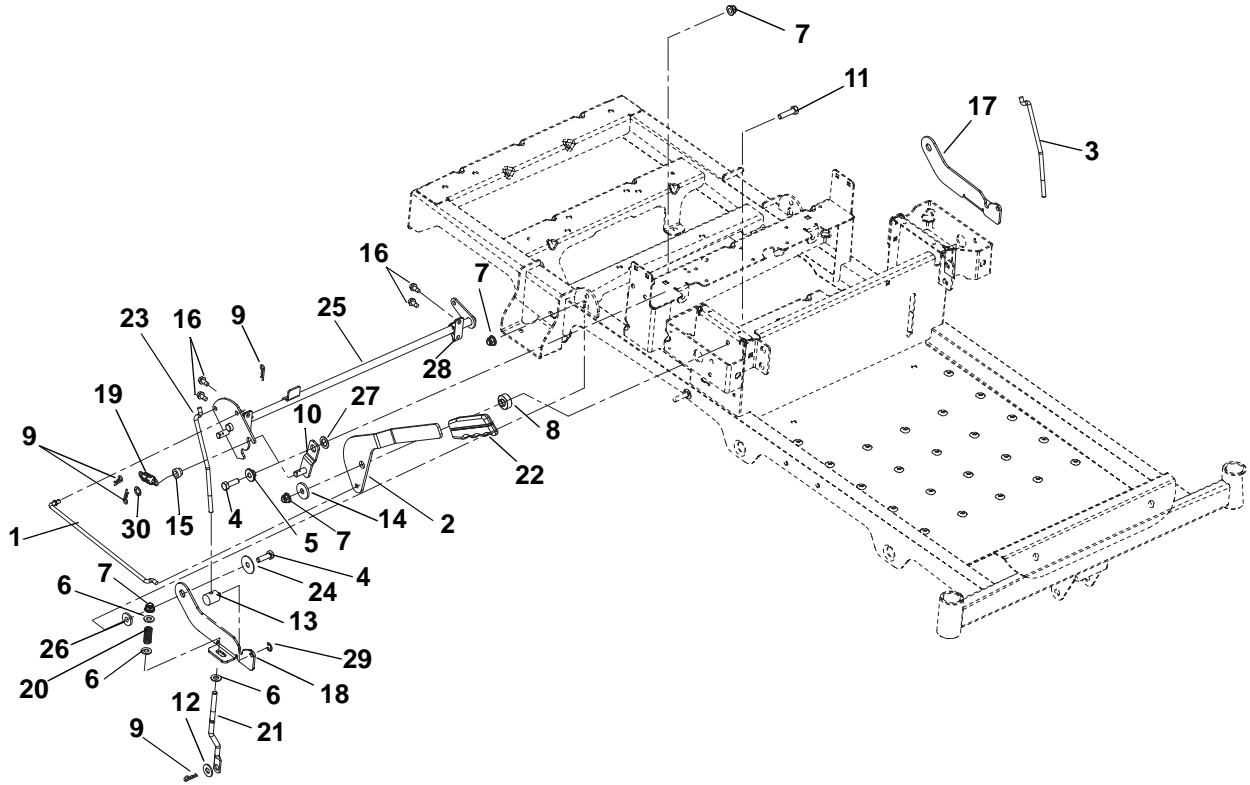

PARKING BRAKE

Model 915146, 148, 150, 168, 170

Item	Part No.	Qty.	Description
1	03759400	1	Link, Brake Handle
2	03759167	1	Handle, Parking Brake
3	03823300	1	Link, Neutral Left Hand
4	05946900	3	Bolt, Hex .31-18 x 1.00
5	05514800	1	Bushing, Flange .312 x .500 x .344 x .880
6	06437200	6	Washer, Flat Steel .344 x .688 x .065
7	06545400	6	Nut, Flange Nyloc 5/16-18
8	03769400	1	Spacer, Brake Handle
9	06713500	5	Pin, Hair Internal .08 x .18 x 1.18
10	03759200	1	Weldment, Detent Arm
11	05947500	1	Bolt, Hex .31-18 x 1.25
12	06435700	2	Washer, Flat Steel .38 x .875 x .083
13	03764800	2	Trunnion, 1/4-20
14	06446300	1	Washer, Flat Steel .344 x 1.125 x .135
15	03764900	1	Roller
16	07400034	4	Screw, Tapping .25-20 x .50 Hex Washer Head
17	03759067	1	Latch, Left Hand Neutral
18	03758967	1	Latch, Right Hand Neutral
19	08326700	1	Spring, Tension .072 x .565 x 1.87
20	08300028	2	Spring, Compression
21	03759667	2	Link, Brake Cog
22	03826900	1	Grip, Parking Brake
23	03759500	1	Link, Neutral Right Hand
24	06446900	2	Washer, Flat Steel .347 x 1.254 x .048
25	03761167	1	Weldment, Brake Shaft
26	01305900	2	Bushing, Flange .325 x .499 x .26 x .88
27	06441100	1	Washer, Flat Steel .52 x .827 x .062
28	03757501	2	Bushing, .50 Clamp Block Molded
29	05700125	2	Ring, Retaining, External .250 x .025
30	06400840	1	Washer, Steel .385 x .745 x .030

STEERING CONTROLS

Model 915146, 148, 150, 168, 170

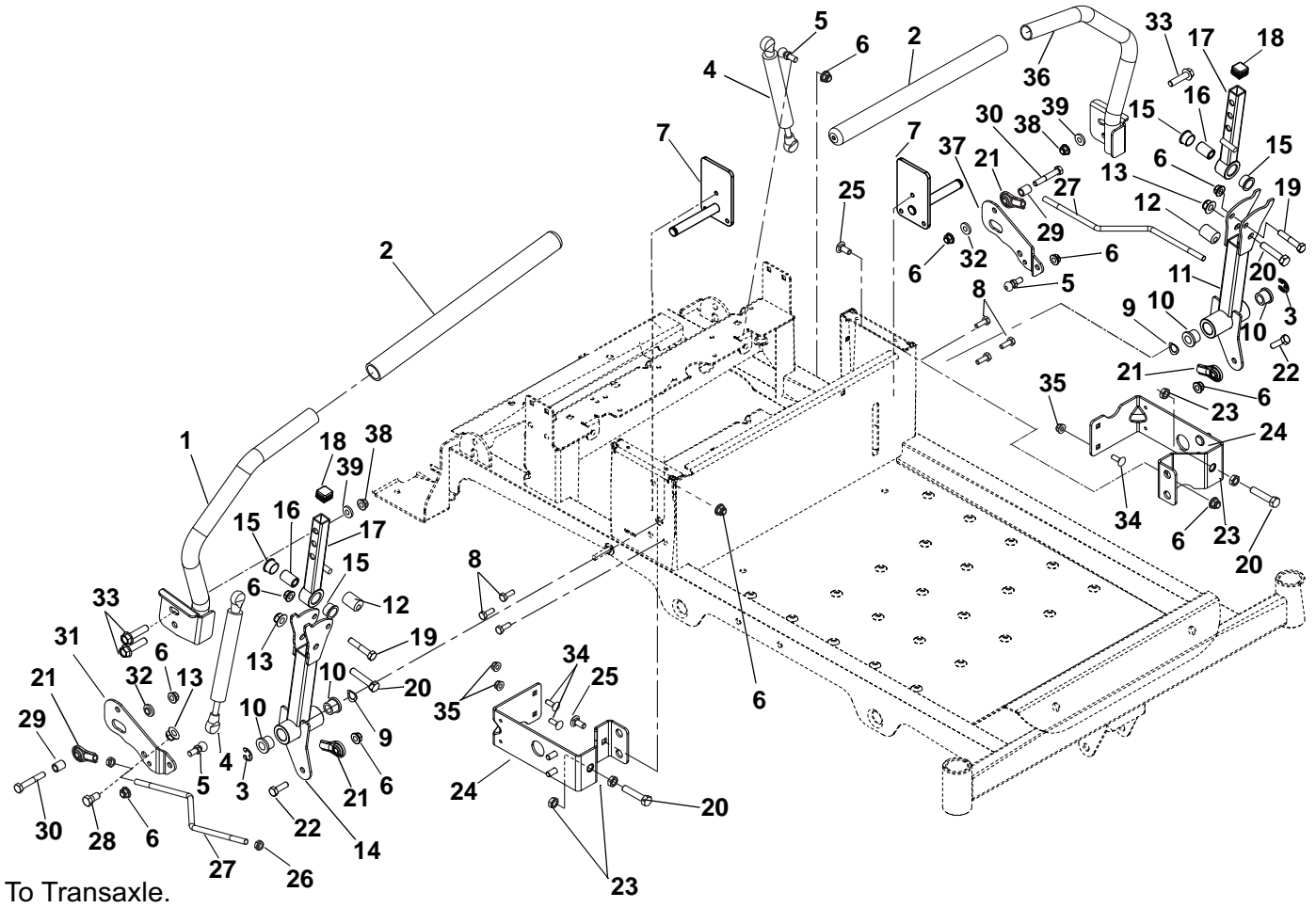

STEERING CONTROLS

Model 915146, 148, 150, 168, 170

Item	Part No.	Qty.	Description
1	04193051	1	Weldment, Steering Handle Right Hand
2	04257400	2	Grip, Handlebar 15" Foam
3	05710200	2	Ring, Retaining External .438 x 1.00 x 0.83
4	03943800	2	Damper
5	03652200	4	Stud, Ball
6	06545400	12	Nut, .31-18 Flange
7	04197651	2	Weldment, Steering Shaft
8	07400034	6	Screw, Tapping .25-20 x .50 Hex Washer Head
9	06400005	2	Washer, Wave
10	05511000	4	Bushing, Flanged
11	04192851	1	Weldment, Lower Control Arm
12	05500932	2	Bushing, Eccentric
13	06545500	4	Nut, .38-16 Nyloc Flange
14	04199451	1	Weldment, Lower Control Right Hand
15	05501017	4	Bushing, Flanged
16	04193500	2	Spacer, .375 x .625 x .970
17	04192951	2	Weldment, Upper Control Arm
18	07500131	2	Cap Plug, Square
19	05957400	2	Bolt, Hex .31-18 x 1.75
20	05974000	4	Bolt, Hex .375-16 x 1.75
21	03787100	4	Alignaball, 5/16 RH Thread
22	05946900	2	Bolt, Hex .31-18 x 1.00
23	06535900	4	Nut, Hex Jam .375-16
24	03956251	2	Bracket, Speed Adjustment/Seat Pivot
25	06220800	2	Bolt, Round Head Square Neck .31-18 x .75
26	06536700	4	Nut, Jam, .31-24
27	04197300	2	Wireform, Steering Link
28	05959400	2	Bolt, Hex .38-16 x .75
29	04208000	2	Spacer, .328 x .500 x .625
30	05957200	2	Bolt, Hex .31-18 x 2.00
31	03759351	1	Plate, Dampener Right Hand
32	04147200	2	Bushing, Flanged
33	07050000	4	Bolt, Serrated Hex Flange Washer Head .375-16 x 1.25
34	06219900	4	Bolt, Round Head Square Neck .25-20 x .75
35	06500012	4	Nut, Locking Nylon Flange .25-20
36	04199551	1	Weldment, Steering Handle Left Hand
37	03766051	1	Plate, Damper Left Hand
38	06537200	4	Nut, Locking Center Jam .375-16
39	06436200	4	Washer, Flat Steel .406 x .812 x .065

ENGINE, EXHAUST, BELTS AND IDLERS

Model 915146, 148, 150, 168, 170

Item	Part No.	Qty.	Description
1	08200638	1	Engine, 16.5 HP Briggs and Stratton Intek without Muffler (915146, 168)
	08200631	1	Engine, Kawasaki FR651 21.5HP (915148, 170)
	08200717	1	Engine, Kawasaki FR691 23HP (915150)
2	07414700	4	Screw, Tapping .38-16 x 1.25 Hex Washer Head(915146, 168)
3	05901507	4	Bolt, Hex .38-16 x 1.25 (915148, 150, 170)
4	06537200	1	Nut, Locking Jam .375-16 (915146, 168)
5	00619600	1	Throttle/Choke Cable (915168)
	06900520	1	Cable, Choke/Throttle Combo (915148, 150, 170)
	06900521	1	Cable, Throttle (915146)
6	07415800	2	Screw, Tapping 10-24 x .50 Hex Washer Head
7	03943600	1	Oil Drain
8	00390100	4	Wire Clip (for .25" hole) (148, 150, 170)
9	03946900	1	Muffler, Twin (915148, 150, 170)
	04058800	1	Muffler, B&S 208 BBZ (915146, 168)
10	06443600	1	Washer, Flat Steel .469 x 2.00 x .25
11	06309300	1	Washer, Locking .44 x .109 Regular
12	05966700	1	Bolt, Hex .44-20 x 4.50 Grade 8
13	07338600	1	Weldment, Crankshaft Extension
14	03972700	1	Clutch, 105 FT*LB MONO Pole
15	06603400	1	Key, Square .25 x 1.25 x .25 SAE 8630 or SAE 1035
16	06225400	1	Bolt, Round Head Square Neck .38-16 x 2.75
17	06442000	1	Washer, Flat Steel .563 x 1.38 x .109
18	06442400	2	Washer, Flat Steel .406 x 1.375 x .135
19	06545500	3	Nut, Locking Nylon Flange .38-16
20	07300221	1	Pulley, Engine Clutch
21	05961400	1	Bolt, Hex .38-16 x 2.75
22	08553700	1	Bushing, Sleeve .391 x .688 x .52
23	08300512	1	Spring, Extension
24	03961100	1	Spacer, Ground Drive Idler
25	03961067	1	Idler Arm, Ground Drive
26	03960700	1	Bushing, Idler Arm
27	05901418	1	Screw, Cap .31-18 x 1.75
28	03980200	1	Spacer, Rubber 5/16 ID x 1.0
29	06530400	2	Nut, Spin Lock Flange .312-18
30	06543100	2	Nut, Locking Top Flange .31-18
31	03956751	1	Bracket, Clutch Stop
32	05960600	1	Bolt, Hex .31-18 x 2.75
33	06545400	1	Nut, Locking Nylon Flange .31-18
34	07200010	1	V-Belt, HA-RAW Edge Laminated
35	06308600	4	Washer, Locking .31 x .078 Regular (915148, 150, 170)
	06308600	2	Washer, Locking .31 x .078 Regular (915146, 168)
36	05933100	4	Capscrew .31-18 x .75 S/HD (915148, 150, 170)
	05933100	2	Capscrew .31-18 x .75 S/HD (915146, 168)
37	03276500	1	Guard, Briggs Engine (915146, 168)
38	06100206	1	Screw, 8-16 x .87 (915146, 168)
39	07400034	2	Screw, Tapping .25-20 x .50 Hex Washer Head (915146, 168)

FUEL TANK

Model 915146, 148, 150, 168, 170

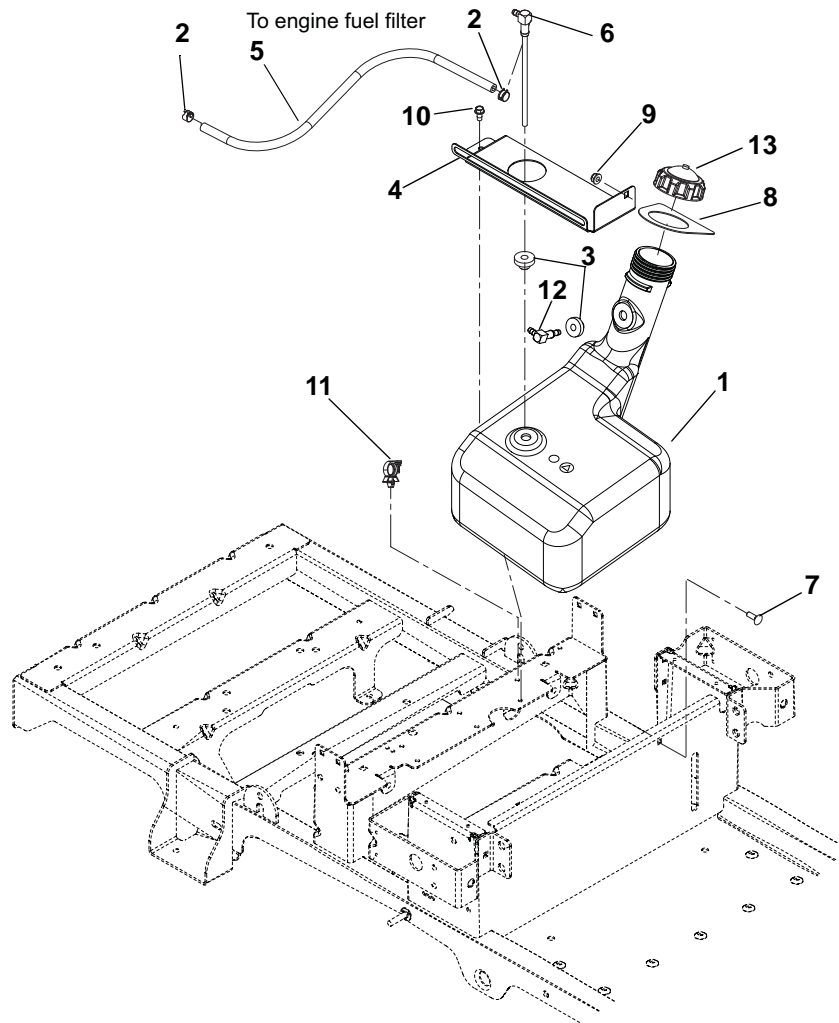

Item	Part No.	Qty.	Description
1	04191900	1	Tank, Fuel with Vent Port
2	03278800	2	Clamp, Fuel Line
3	07500206	2	Bushing
4	03771451	1	Bracket, Tank Strap
5	03278100	NA	Hose, .25 Low Perm Gas (as required)
6	04333600	1	Assembly, Fuel Pickup
7	06219900	1	Bolt, Round Head Square Neck .25-20 x .75
8	03795700	1	Seal, Tank Neck
9	06500012	1	Nut, .25-20 Nyloc Flange
10	07400034	1	Screw, Tapping .25-20 x .50 Hex Washer Head
11	00390100	1	Wire Clip
12	04382800	1	Fitting, 90 Degree Fuel Plastic
13	04238500	1	Fuel Cap, 225 CARB with 12" THTR

CONTINUITY DIAGRAM

Model 915146, 148, 150, 168, 170

The diagrams below show the various states of connection for electrical components.
 The solid lines on switches show continuity.
 NOTE: All switches are viewed from the rear.

Key Switch
(03290500)

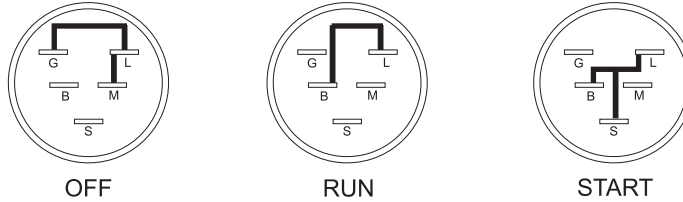

PTO Switch
(04399600)

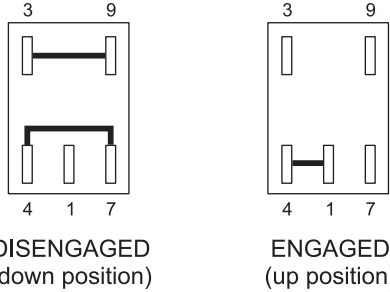

Relay
(03042800)

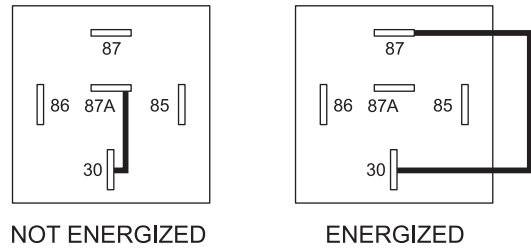

Seat Switch
(03654200)

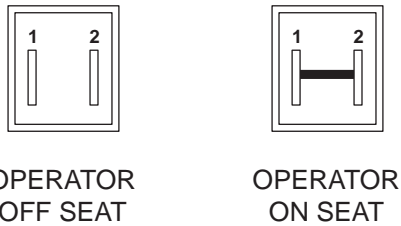

Park Brake Switch
(03606600)

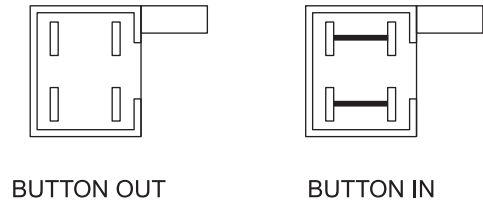

Solenoid
(00696900)

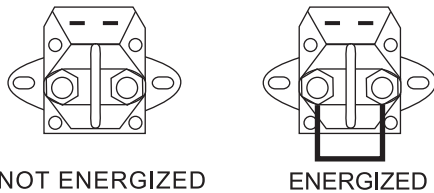

PE0771

ELECTRICAL SYSTEM

Model 915146, 148, 150, 168, 170

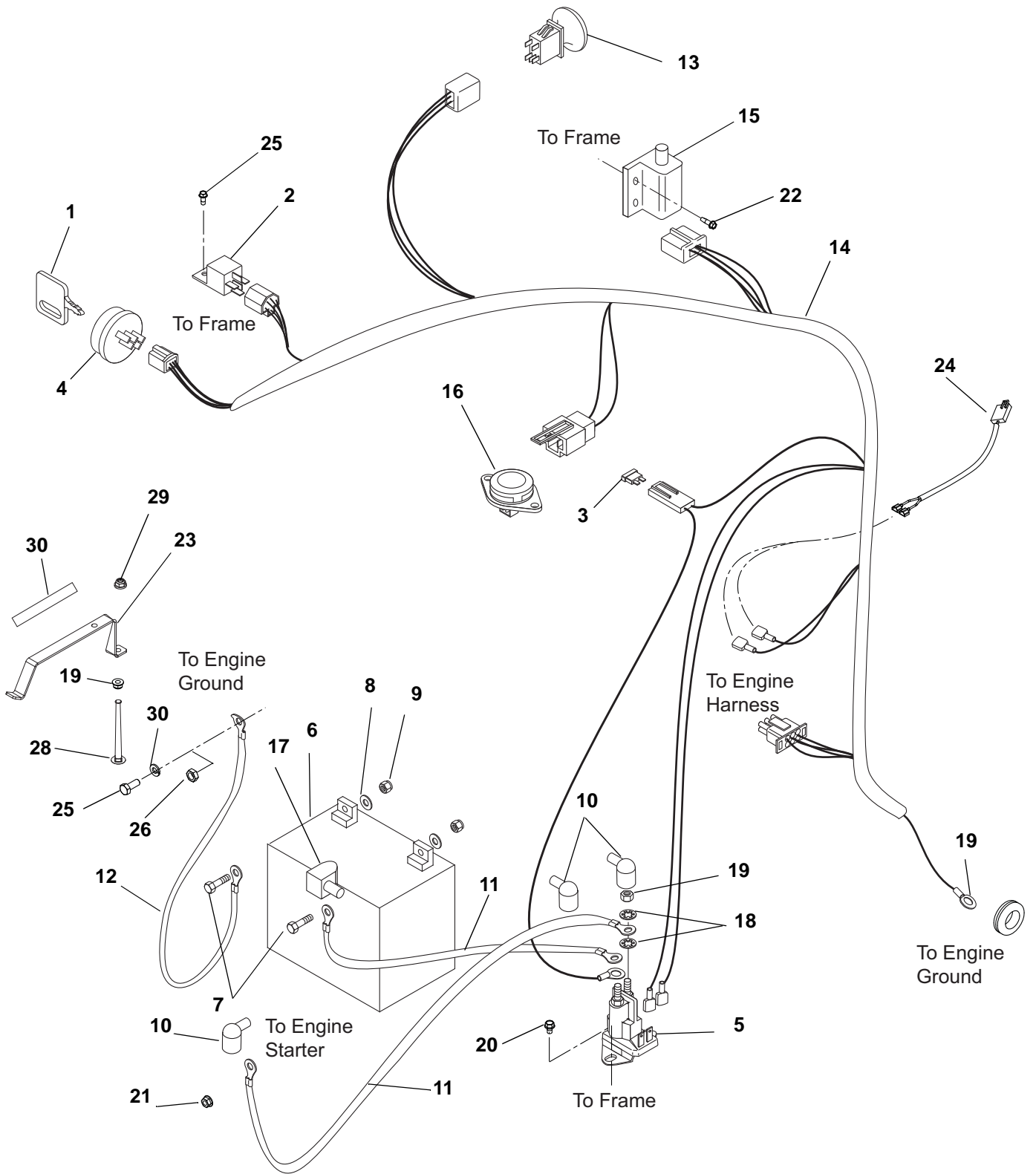

PE0200_A_G_Electrical

ELECTRICAL SYSTEM

Model 915146, 148, 150, 168, 170

Item	Part No.	Qty.	Description
1	03927000	1	Key
2	03042800	1	Relay
3	09351100	1	Fuse, 30 AMP
4	03290500	1	Key Switch with Key
5	00696900	1	Solenoid
6	04382200	1	Battery, 12V 20 Hour (Can be replaced with U1 190 or larger)
7	05946800	2	Bolt, Hex .25-20 x .75
8	06437300	2	Washer, Flat Steel .281 x .62 x .065
9	06509200	2	Nut, KEPS .250-20
10	07533200	3	Boot, Eyelet Terminal
11	04249800	2	Cable, POS
12	04249900	1	Ground Cable
13	04399600	1	Switch, Clutch With Retainer
14	03773900	1	Harness, Wiring ZT
15	03606600	1	Switch, Double Pole N.O. / N.O.
16	03654200	1	Switch, Snap Mounting (N.O.)
17	07505700	1	Insulator
18	06310500	4	Washer, Locking .31
19	06536700	2	Nut, Jam .31-24
20	07411600	2	Screw, Tapping .250-20 x .37 Hex Washer Head
21	06543500	1	Nut, Locking Top Flange .25-20
22	07400038	2	Screw, 12-14 x .75 HX
23	04385351	1	Hold Down, Battery
24	03972600	1	Harness, Clutch
25	07411900	1	Screw, Tapping 12-24 x .50 Hex Washer Head
26	06537200	1	Nut, Locking Center Jam .375-16 (915146, 168)
27	00390100	1	Wire Clip (915148, 150, 170)
28	06200211	1	Bolt, Round Head Square Neck .25-20 x 4.50
29	06500012	1	Nut, Locking Nylon Flange .25-20
30	07800336	1	Decal, U1 Battery Replacement

WIRING DIAGRAM

Model 915146, 148, 150, 168, 170

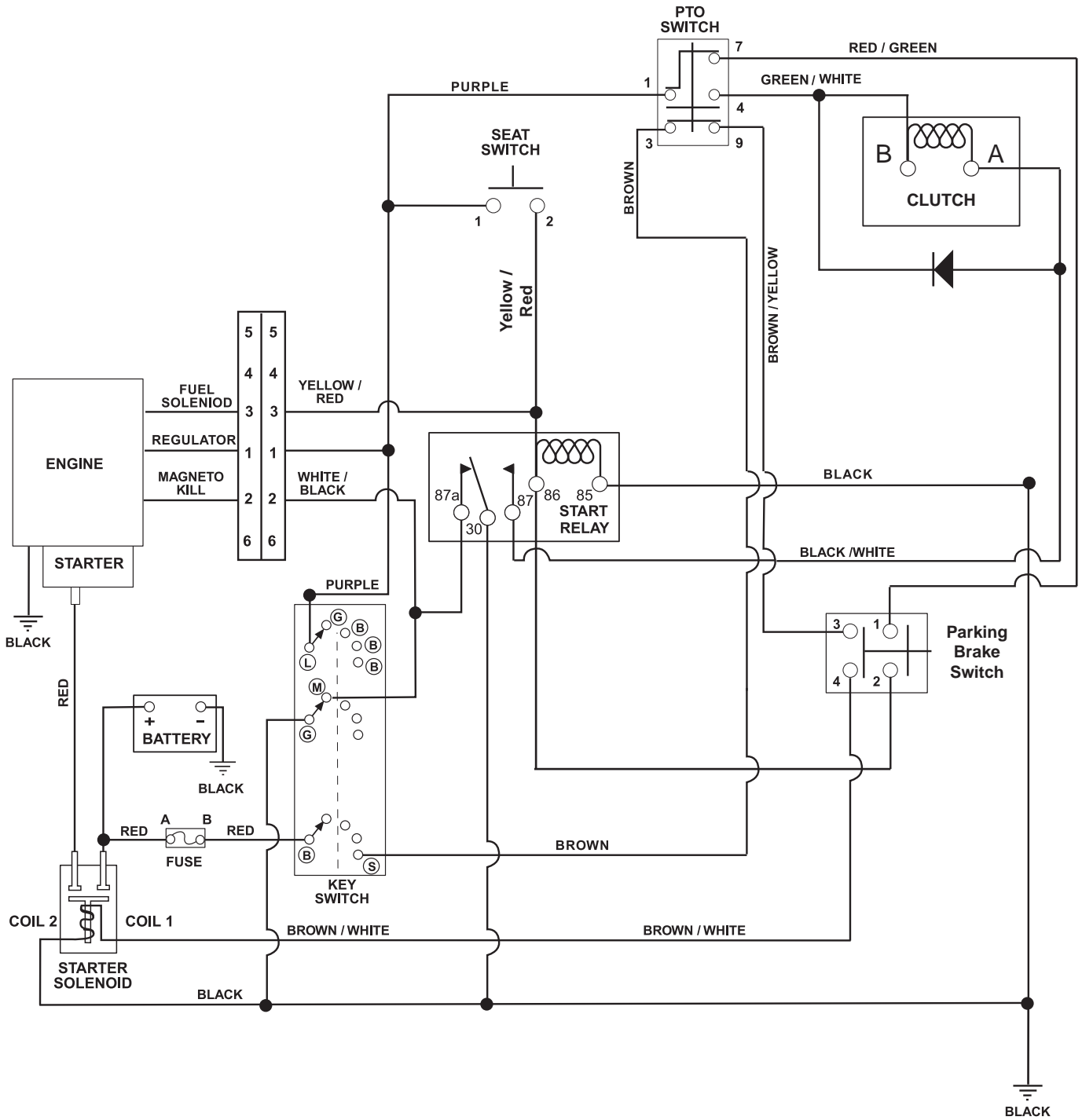

NOTES

MOWER DECK LIFT

Model 915146, 148, 150, 168, 170

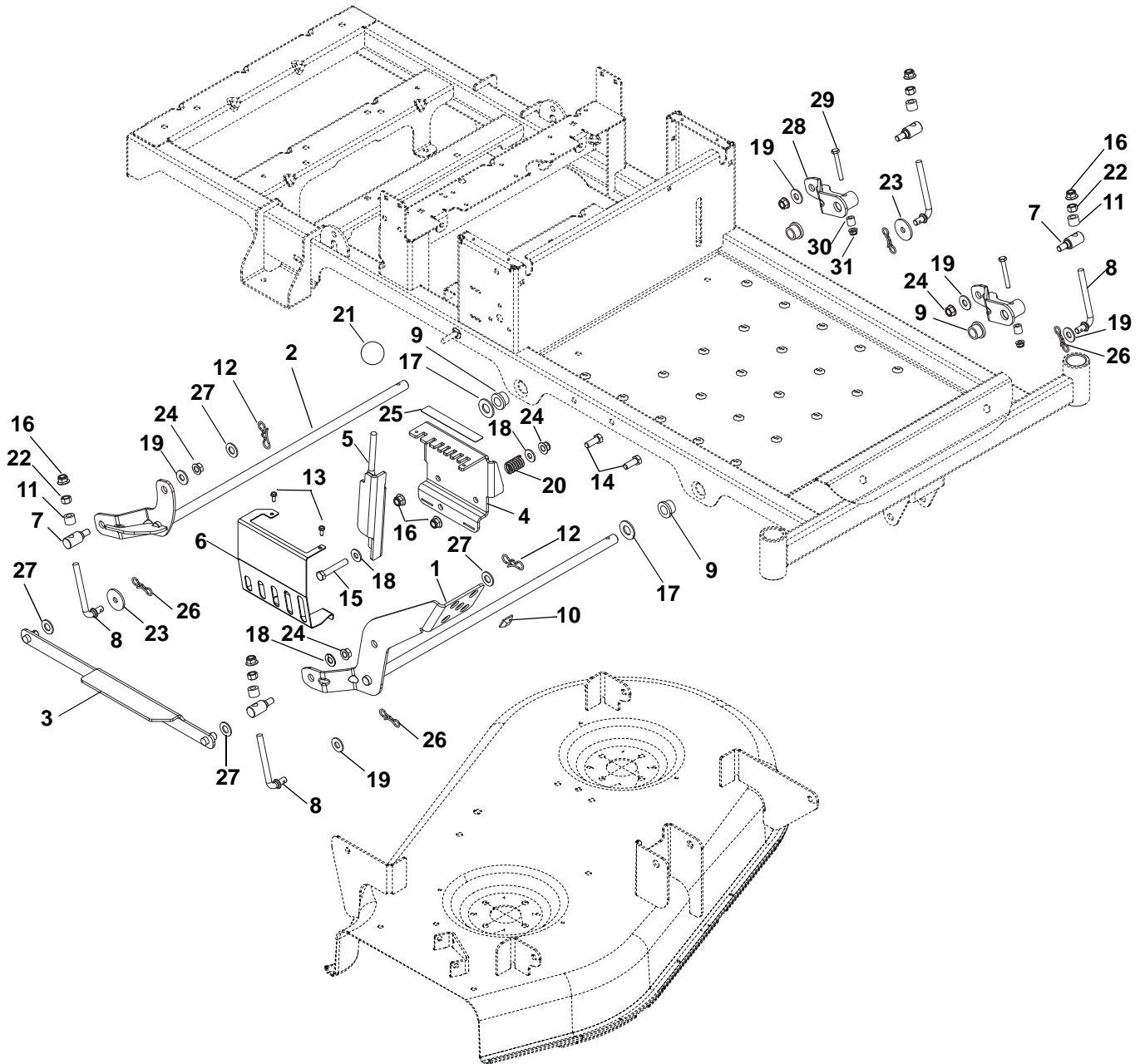

MOWER DECK LIFT

Model 915146, 148, 150, 168, 170

Item	Part No.	Qty.	Description
1	04434567	1	Weldment, Footpedal
2	04434467	1	Weldment, Rear Deck Lift
3	04377367	1	Weldment, Lift/HOC Link
4	04377951	1	Plate, Height Adjustment
5	04391567	1	Weldment, Height of Cut
6	04723751	1	Guard, Deck HOC
7	04377867	4	Trunion, Deck Adjuster
8	04377767	4	Wireform, Deck Adjustment
9	05519100	4	Bushing, Flange .629 x .879 x .469 x 1.25
10	07525100	1	Stop
11	08553700	4	Bushing, Sleeve .391 x .688 x .52
12	06700201	2	Pin, Bow Tie Locking Cotter .091 x 1.875
13	07415800	2	Screw, Tapping, Hex Washer Head Rolling 10-24 x .50
14	05948700	2	Bolt, Hex .38-16 x 1.00
15	05962900	1	Bolt, Hex .38-16 x 2.25
16	06545500	7	Nut, Locking Nylon Flange .38-16
17	06442800	2	Washer, Flat Steel .656 x 1.31 x .095
18	06435700	3	Washer, Flat Steel .38 x .875 x .083
19	06436200	5	Washer, Flat Steel .438 x 1.00 x .083
20	08335700	1	Spring, Compression .125 x .781 x 1.25
21	07533500	1	Knob, Ball – Black 1.47" .375-16
22	06529400	4	Nut, Hex .38-16
23	06443400	2	Washer, Flat Steel .380 x 1.50 x .125
24	06542000	4	Nut, Locking Top Flange .38-16
25	07800334	1	Decal, Height of Cut
26	06700206	4	Pin, Bowtie Locking
27	06443300	4	Washer, Flat Nylon .518 x 1.00 x .08
28	04434667	2	Weldment, Deck Lift Arm
29	05967100	2	Bolt, Hex .25-20 x 2.00
30	05501112	2	Bushing, Sleeve .265 x .500 x .500
31	06500012	2	Nut, Locking Nylon Flange .25-20

MOWER DECK, BELT AND IDLERS

Model 915146, 168

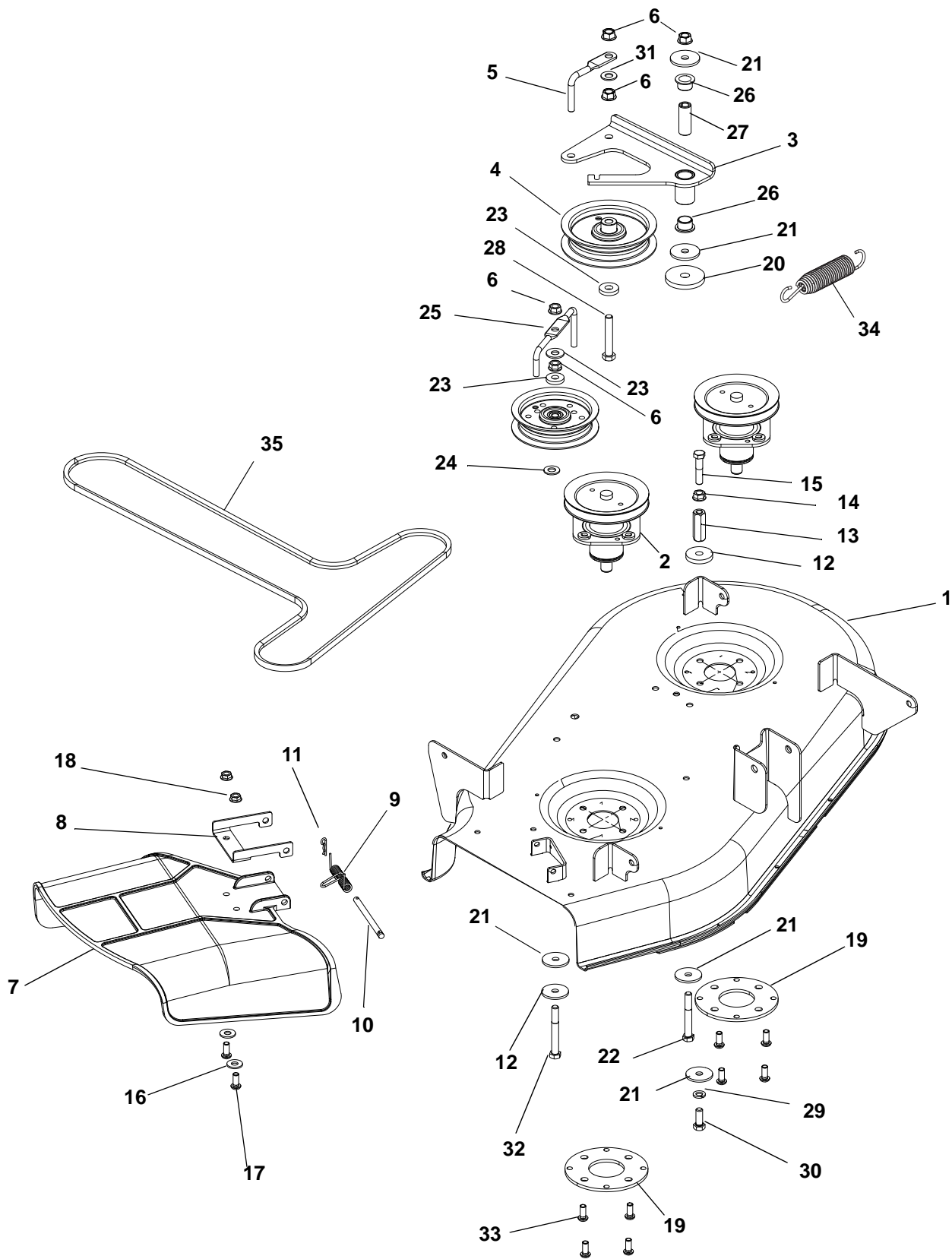

MOWER DECK, BELT AND IDLERS

Model 915146, 168

Item	Part No.	Qty.	Description
1	51525700	1	Kit, Gravely 34" Deck wtiH Decals
2	61559900	2	Assembly, Spindle
3	04430867	1	Weldment, Idler Arm
4	07300039	2	Assembly, Idler 4"
5	03828853	1	Wireform, Belt Finger
6	06542000	5	Nut, Locking Top Flange .38-16
7	03994300	1	Chute, Side Discharge
8	00662653	1	Chute Reinforcement
9	01258100	1	Spring, Torsion
10	06800002	1	Pin, 5/16 x 3.88"
11	06713500	1	Pin, Hair Internal .08 x .18 x 1.18
12	06400006	2	Washer, Flat Steel .406 x 1.50 x .245
13	06533500	1	Nut, Coupling .375-16 x 1.75
14	06534900	1	Nut, Spin Lock, Flange .375-16
15	05958500	1	Bolt, Hex .38-16 x 1.75
16	06435700	2	Washer, Flat Steel .38 x .875 x .083
17	05920900	2	Screw, Socket Head .31-18 x .75 Button Head
18	06543100	2	Nut, Locking Top Flange .31-18
19	03839053	2	Plate, REINF, Spindle
20	06443600	1	Washer, Flat Steel .469 x 2.00 x .25
21	06443400	5	Washer, Flat Steel .380 x 1.50 x .125
22	05957800	1	Bolt, Hex .38-16 x 3.00
23	06444000	3	Washer, Flat Steel .406 x 1.00 x .188
24	06435900	1	Washer, Flat Steel .438 x 1.00 x .083
25	03974153	1	Belt Finger
26	05500907	2	Bushing, Flange, .625 x .750 x .500 x 1.00
27	03763400	1	Spacer, .375ID x .625D x 1.66 Promaster
28	05962900	1	Bolt, Hex .38-16 x 2.25
29	06308800	1	Washer, Locking .38 x .094 Regular
30	05948700	1	Bolt, Hex .38-16 x 1.00
31	064362001		Washer, Flat Steel .406 x .812 x .065
32	05961400	1	Bolt, Hex .38-16 x 2.75
33	07415400	8	Screw, Tapping .38-16 x .75 Hex Washer Head Thread Rolling
34	08320300	1	Spring, Tension .135 x .98 x 6.0
35	07200116	1	V-Belt, HA-Wrapped Clutching

MOWER DECK, BELT AND IDLERS

Model 915148, 150, 170

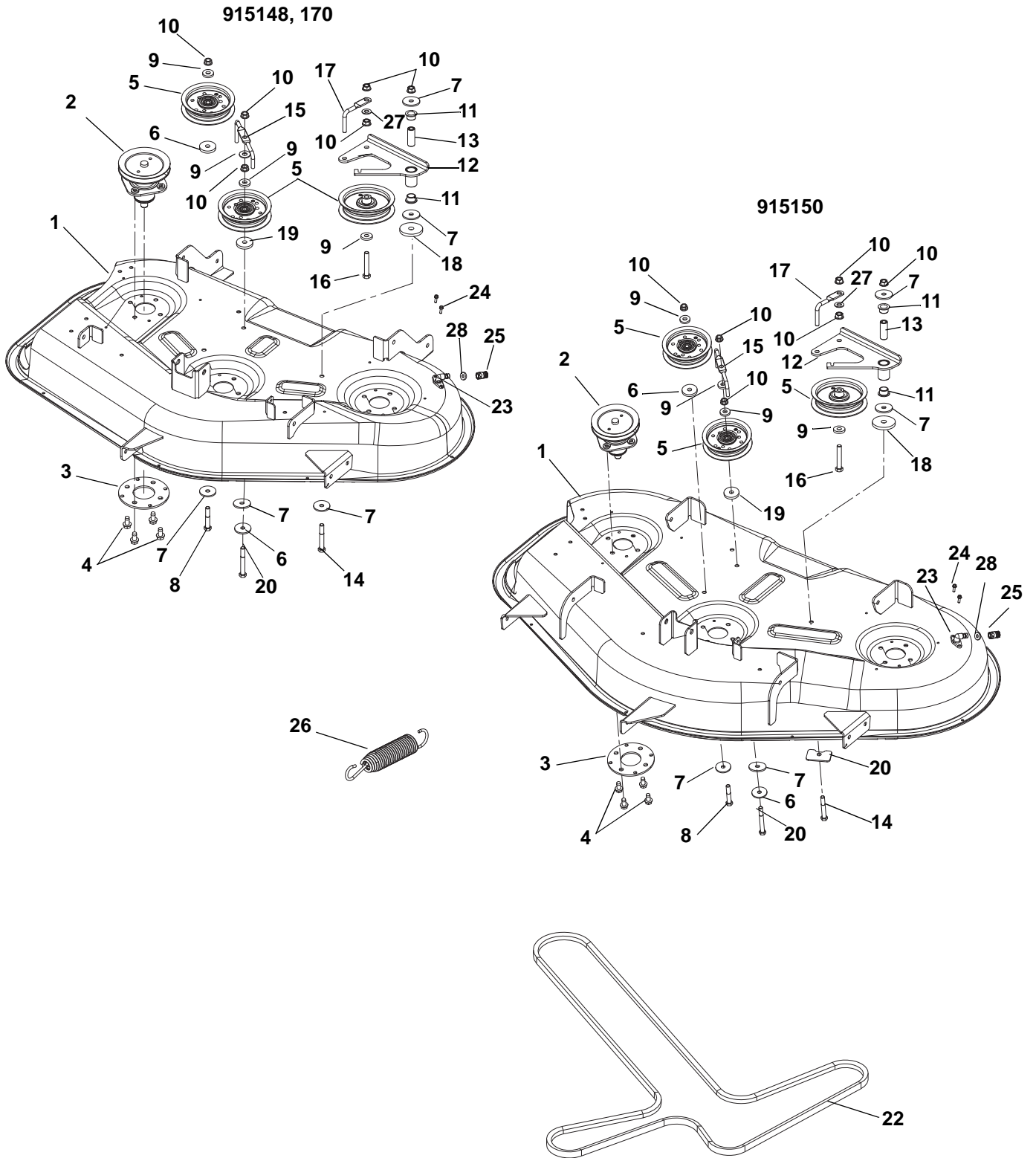

MOWER DECK, BELT AND IDLERS

Model 915148, 150, 170

Item	Part No.	Qty.	Description
1	51523800	1	Kit, Gravely 42" Deck with Decals (915148, 170)
	51523900	1	Kit, Gravely 50" Deck with Decals (915150)
2	51520900	3	Assembly, Spindle (915148, 170)
	51519500	3	Assembly, Spindle (915150)
3	03839053	3	Plate, Spindle
4	07415400	12	Screw, Tapping .38-16 x .75 Hex Washer Head
5	07300039	3	Assembly, Idler 4"
6	06400006	2	Washer, Flat Steel .406 x 1.50 x .245
7	06443400	5	Washer, Flat Steel .380 x 1.50 x .125 (915148, 170)
	06443400	4	Washer, Flat Steel .380 x 1.50 x .125 (915150)
8	05962900	1	Bolt, Hex .38-16 x 2.25
9	06444000	4	Washer, Flat Steel .406 x 1.00 x .188
10	06542000	5	Nut, Locking Top Flange .38-16
11	05500907	2	Bushing, Flange, .625 x .750 x .500 x 1.00
12	04430867	1	Idler Arm
13	03763400	1	Spacer, .375ID x .625 OD x 1.66
14	05957800	1	Bolt, Hex .38-16 x 3.00
15	03974153	1	Belt Finger
16	05962900	1	Bolt, Hex .38-16 x 2.25
17	03828853	1	Wireform Belt Finger
18	06443600	1	Washer, Flat Steel .469 x 2.00 x .25
19	06435900	1	Washer, Flat Steel .438 x 1.00 x .083
20	05961400	1	Bolt, Hex .38-16 x 2.75
21	04061053	1	Plate, Deck (915150)
22	07200523	1	V-Belt, 4L Wrapped (915148, 170)
	07200524	1	V-Belt, 4L Wrapped (915150)
23	04428900	1	Assy, Washout Port W/O Ring
24	07400103	2	Screw, Tapping .25-20 x .62 Hex Washer Head Thread Rolling
25	04396500	1	Coupling, Quick Disconnect
26	08320300	1	Extension Spring .135 x .98 x 6.0
27	06436200	1	Washer, Flat Steel .406 x .812 x .065
28	05600513	1	O-Ring .362 X .103 X .568

BELT COVERS AND BLADES

Model 915146, 168

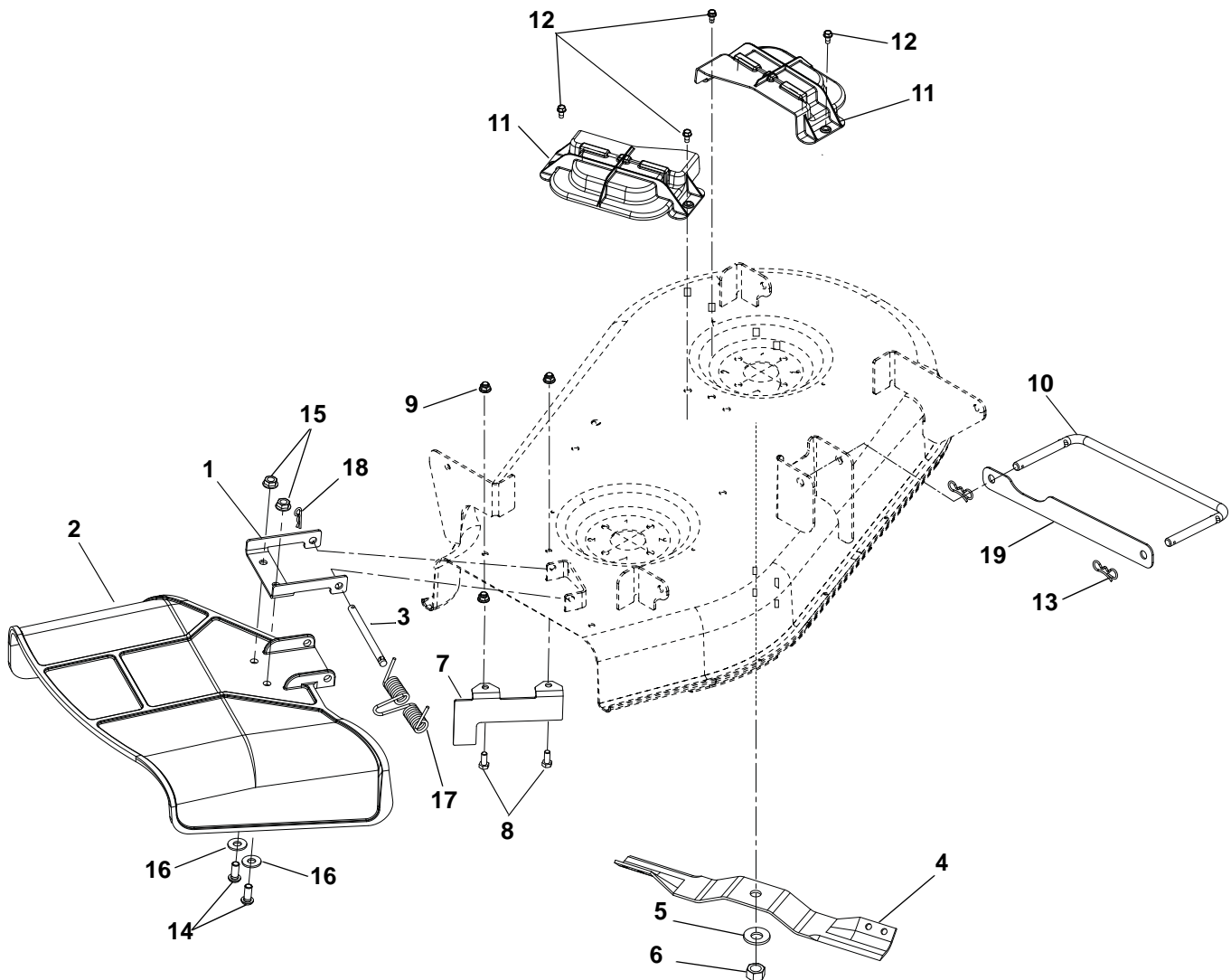

Item	Part No.	Qty.	Description
1	00662653	1	Chute Reinforcement
2	03994300	1	Molded Chute
3	06800002	1	Pin, 5/16 x 3.88"
4	03971900	2	Blade, Mower 17.35
5	06445700	2	Washer, Beveled .63 x 1.625 x .14
6	06500630	2	Nut, Hex .62-18
7	03779253	1	Bracket, Baffle Discharge 34"
8	05947000	2	Bolt, Hex .31-18 x .75
9	06545400	2	Nut, .31-18 Nyloc Flange
10	04377667	1	Wireform, Drag Link
11	04323800	2	Molded Cover, Belt
12	07400034	4	Screw, Tapping .25-20 x .50 Hex Washer Head
13	06700201	2	Pin, Bow Tie Locking Cotter .091 x 1.875
14	05920900	2	Screw, .31-18 x .75
15	06543100	2	Nut, Locking Top Flange .31-18
16	06435700	2	Washer, Flat Steel .38 x .875 x .083
17	01258100	1	Spring, Torsion
18	06713500	1	Pin, Hair .08 x .18 x 1.18
19	04424951	1	Strap, Drag Link

NOTES

BELT COVERS AND BLADES

Model 915148, 150, 170

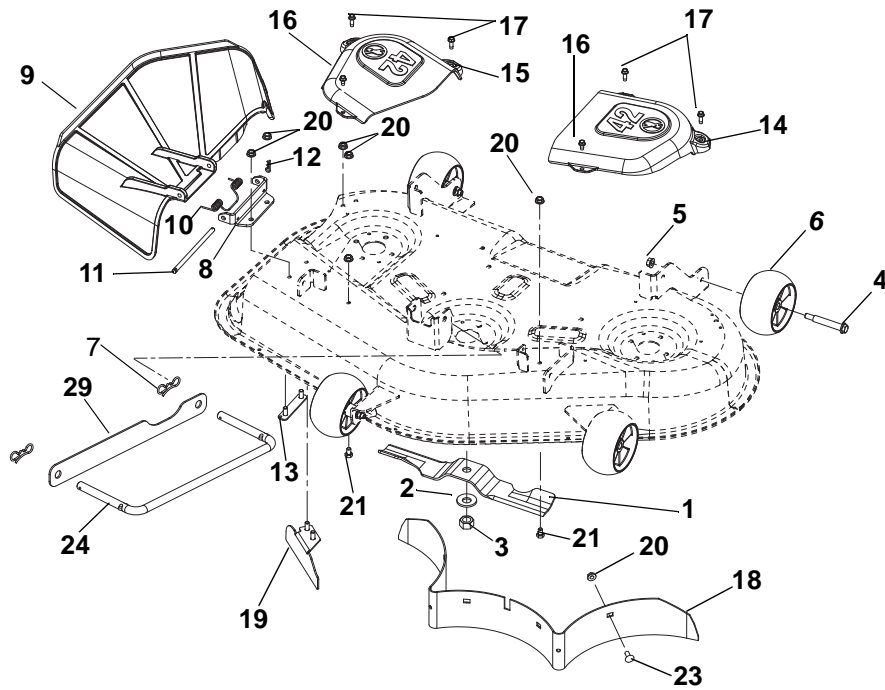

915148, 170

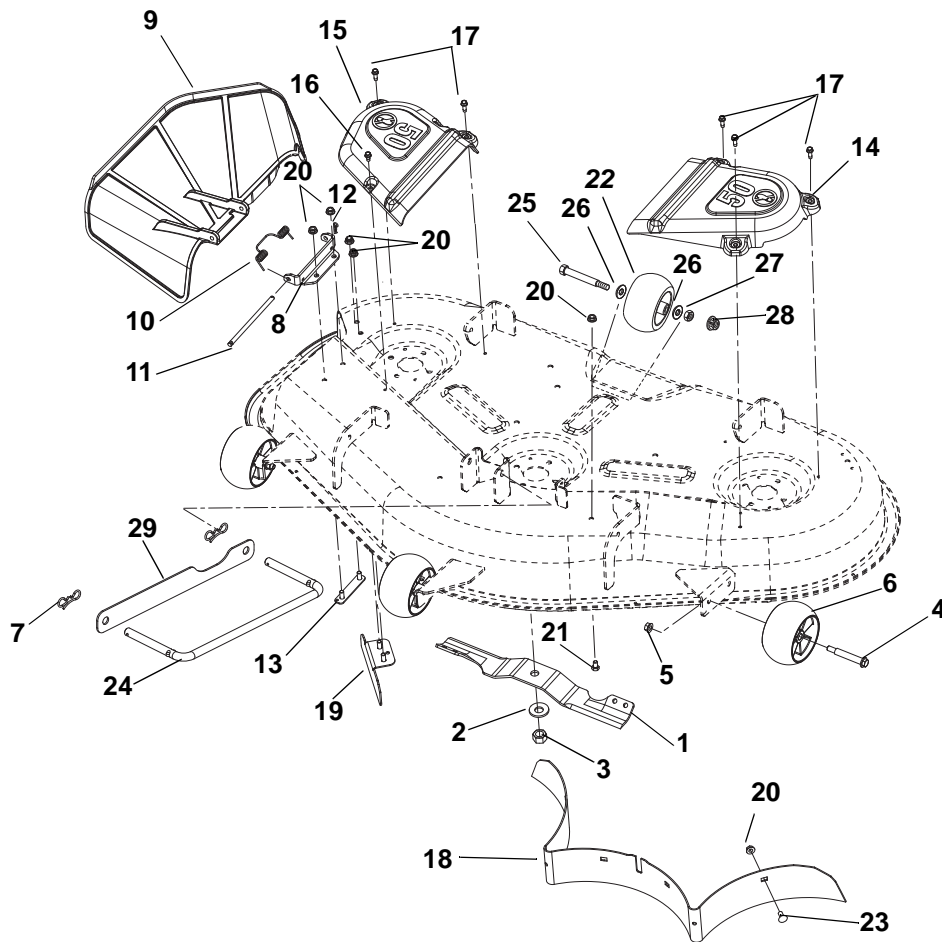

915150

BELT COVERS AND BLADES

Model 915148, 150, 170

Item	Part No.	Qty.	Description
1	04265400	3	Mower Blade, 14.83" (915148, 170)
	03971900	3	Blade, Mower 17.35" (915150)
2	06445700	3	Washer, Bellville .63 x 1.625 x .14
3	06500630	3	Nut, Hex .62-18
4	07056800	3	Bolt, Shoulder .38-16 x 2.50 Hex Washer Head
5	06542000	3	Nut, Locking Top Flange .38-16
6	03905600	4	Anti-Scalp Wheel, 5 x 3 OS (915148, 170)
	03905600	3	Anti-Scalp Wheel, 5 x 3 OS (915150)
7	06700201	2	Pin, Bow Tie Locking Cotter .091 x 1.875
8	04073053	1	Bracket, Discharge Chute Mount 42" (915148, 170)
	04443153	1	Bracket, Discharge Chute Mount 50" (915150)
9	04375900	1	Discharge Chute – Molded
10	08300515	1	Spring, Torsion
11	00475800	1	Pin, 5/16 x 5.80"
12	06713500	1	Pin, Hair Internal .08 x .18 x 1.18
13	03977400	1	Weldment, Discharge Chute MT. Strap
14	03902200	1	Belt Cover, Left Hand 42" (915148, 170)
	03901900	1	Belt Cover, Left Hand 50" (915150)
15	03902100	1	Belt Cover, Right Hand 42" (915148, 170)
	03901800	1	Belt Cover, Right Hand 50" (915150)
16	07400034	2	Screw, Tapping .25-20 x .50 Hex Washer Head (915148, 170)
	07400034	1	Screw, Tapping .25-20 x .50 Hex Washer Head (915150)
17	07414200	4	Screw, Tapping .25-20 x .75 Hex Washer Head
18	03957853	1	Baffle, 42 Rear (915148, 170)
	04069053	1	Baffle, 50 Rear (915150)
19	04395453	1	Weldment – Baffle, Discharge 42" (915148, 170)
	03955953	1	Baffle, 50" Deflector (915150)
20	06543100	10	Nut, Locking Top Flange .31-18
21	05947200	2	Bolt, Hex .31-18 x .50
22	02745400	1	Roller (915150)
23	06220800	1	Bolt, Round Head Square Neck .31-18 x .75
24	04377667	2	Wireform, Drag Link
25	05960900	2	Bolt, Hex .38-16 x 3.50
26	06436200	2	Washer, Flat Steel .406 x .812 x .065
27	06537200	2	Nut, Locking Center Jam .375-16
28	06545500	1	Nut, Locking Nylon Flange .38-16
29	04424951	1	Strap, Drag Link



Gravelly
655 West Ryan Street
Brillion, WI 54110
920-756-4688
Fax 920-756-2407
www.gravelly.com

An *Ariens* Company Brand